

| | | | | |
|------------------|-----------|-----------------------------|--------------|-----|
| DRAWN kciampi | 8/23/2013 | TITLE TABLE ASSEMBLY | | |
| CHECKED | | | | |
| QA | | | | |
| MFG | | | | |
| APPROVED | | SIZE A | DWG NO | REV |
| | | SCALE | SHEET 1 OF 4 | |

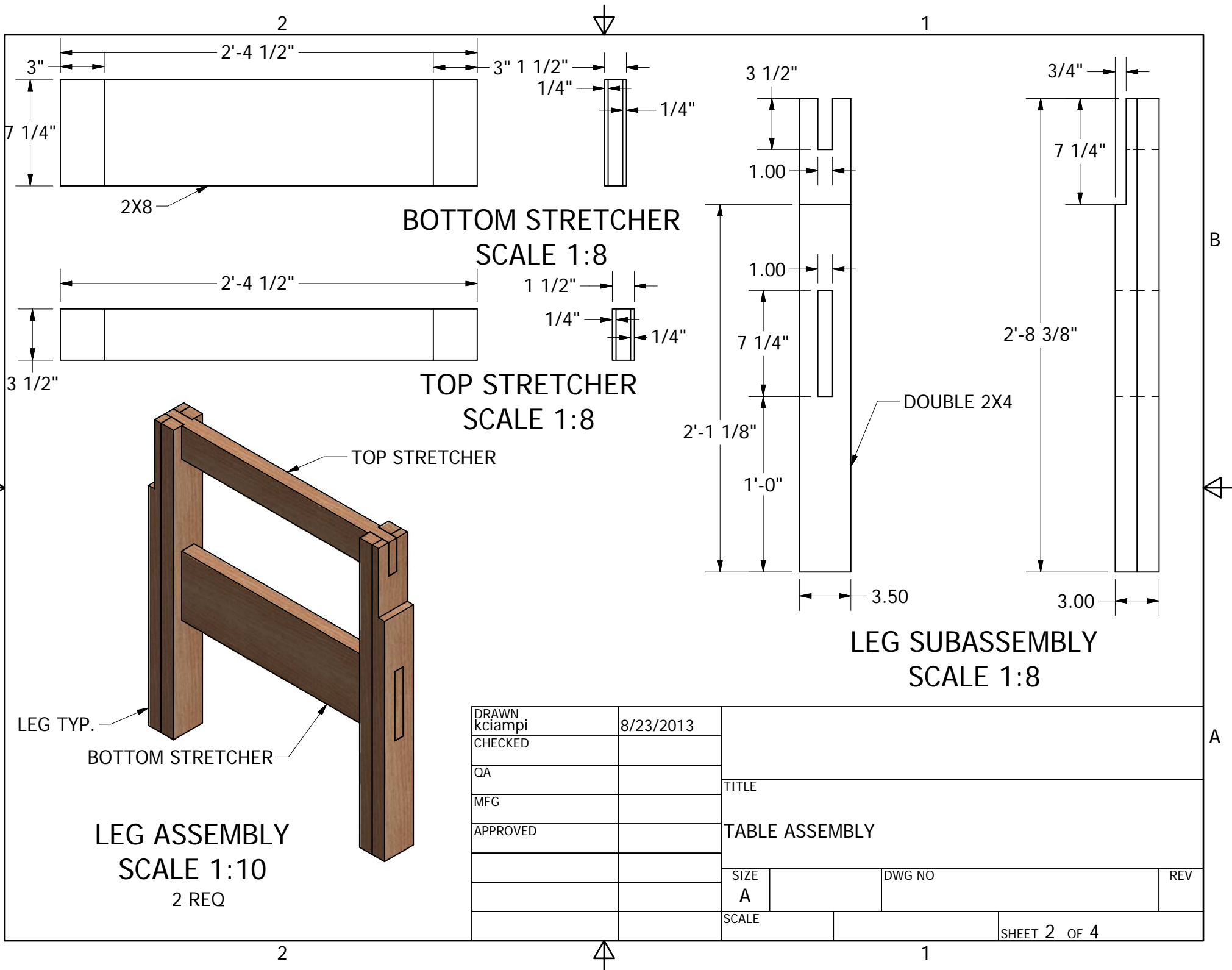

| | | | | |
|------------------|-----------|-----------------------------|--------------|-----|
| DRAWN kciampi | 8/23/2013 | TITLE TABLE ASSEMBLY | | |
| CHECKED | | | | |
| QA | | | | |
| MFG | | | | |
| APPROVED | | SIZE A | DWG NO | REV |
| | | SCALE | SHEET 2 OF 4 | |

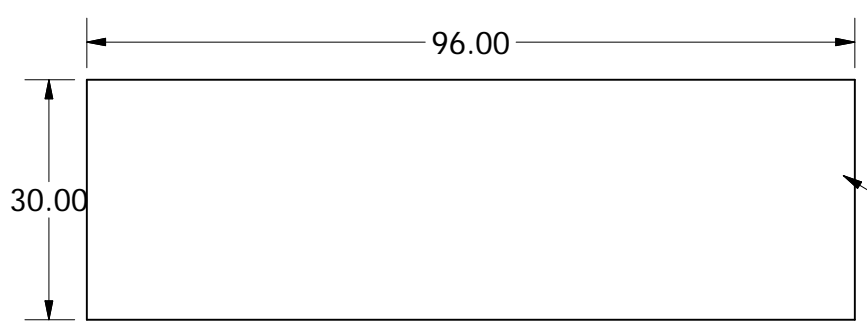
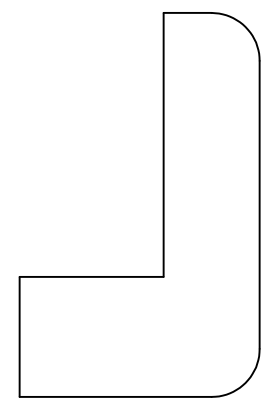
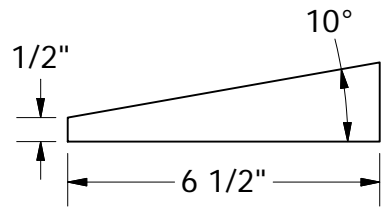

TABLE TOP
SCALE 1:24

CUT ONE 3/4" MELAMINE TOP,
AND ONE 5/8" PLYWOOD SUB



MOLDING PROFILE
SCALE 1:1
TWO 8'-1" AND TWO 2'-7"
LENGTHS REQUIRED



WEDGE
SCALE 1:4
4 REQ



STRINGER
SCALE 1:8
7 REQ

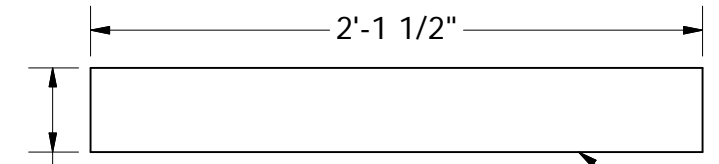

STRINGER
SCALE 1:8
7 REQ

| | | | |
|------------------|-----------|----------------|--------|
| DRAWN kciampi | 8/23/2013 | | |
| CHECKED | | | |
| QA | | TITLE | |
| MFG | | TABLE ASSEMBLY | |
| APPROVED | | SIZE A | DWG NO |
| | | SCALE | REV |
| | | SHEET 3 OF 4 | |

B

B

A

A

2

1

2

1

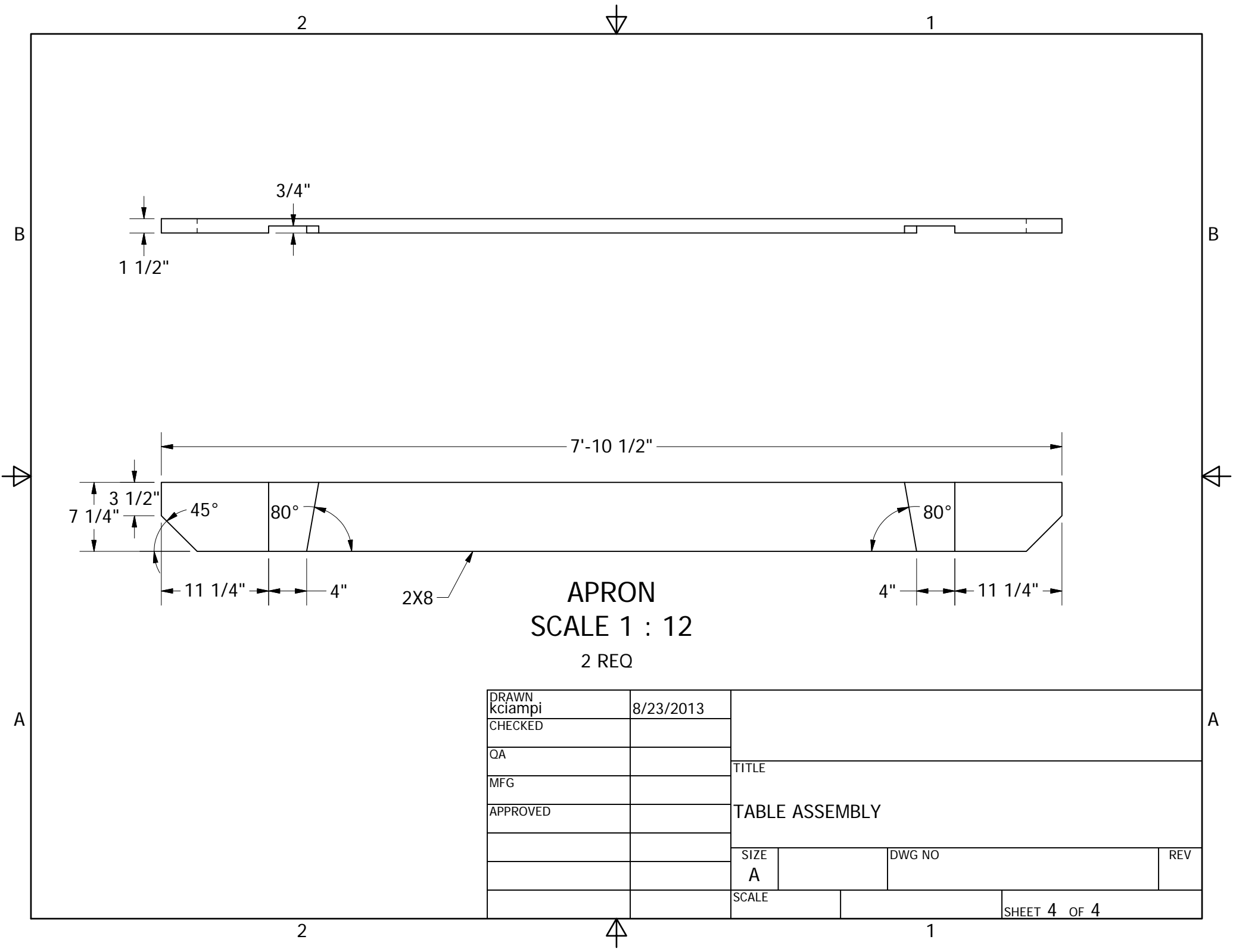

APRON
SCALE 1 : 12

2 REQ

| | | | | |
|------------------|-----------|-----------------------------|--------------|-----|
| DRAWN kciampi | 8/23/2013 | TITLE TABLE ASSEMBLY | | |
| CHECKED | | | | |
| QA | | | | |
| MFG | | | | |
| APPROVED | | SIZE A | DWG NO | REV |
| | | SCALE | SHEET 4 OF 4 | |